

MINIDUMPER HS400 CON KIT EDILE AUTOCARICANTE

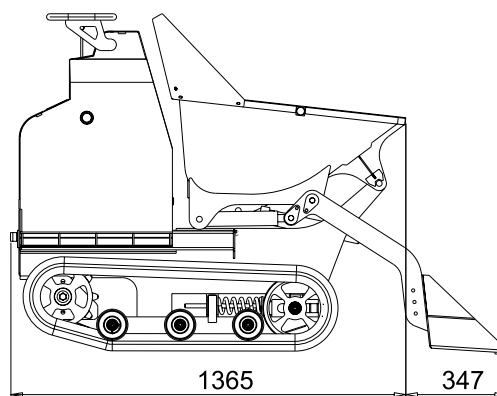

MINIDUMPERS

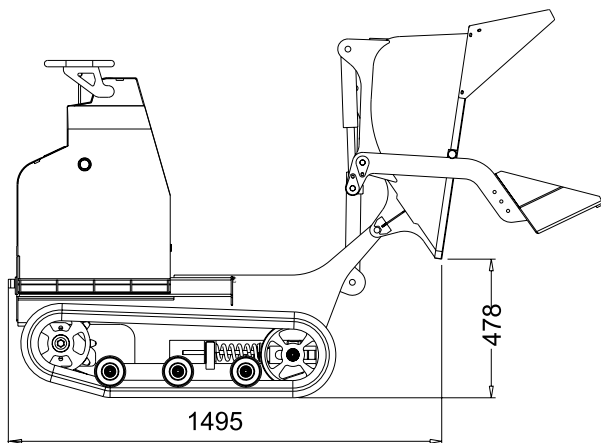
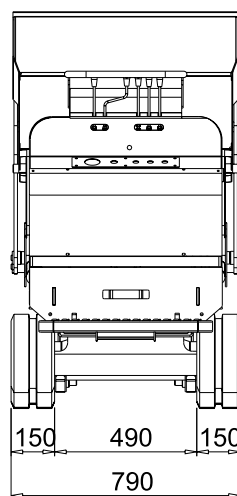
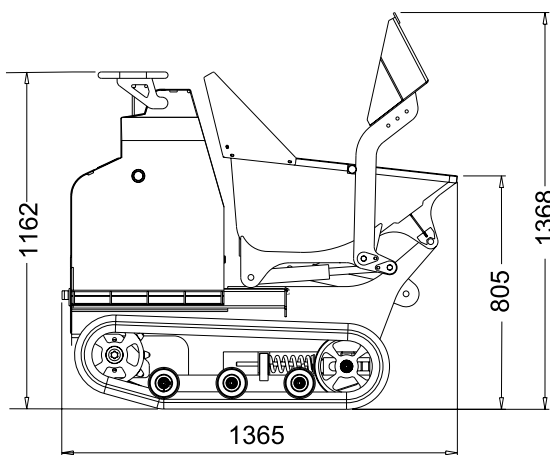

MINIDUMPER HS400 CON KIT EDILE AUTOCARICANTE

G MOTORE BENZINA

Marca.....HONDA
TipoG.....GX200
Cilindri e cilindratamonocilindrico 196 cc
Potenza lorda max. @ rpm6,5 cv - 4,8 kw @ 3600 rpm
Regime di taratura3600 rpm
Avviamentoa strappo
Prestazionipendenza max superabile 25° (circa 60%)
Potenza sonora garantitaLwa 101dB

DISTRIBUTORE

Tipomeccanico

POMPA IDRAULICA

Numero e tipon° 2 ad ingranaggi
Portata litri minuton° 2 x 10.5 lpm
Pressione110 bar

MOTORI DI TRAZIONE

Cilindrata250 cc

CINGOLATURA

Tendicingoloa molla
MarcaMinitop
Dimensionimm 160 x 33 x72
Rulli per lato3
Velocità di traslazione.....1,7 km/h
Carreggiata fissamm 680

PORTATA (compreso kit)kg 450

PESO OPERATIVO (escluso operatore)kg 316

SERBATOIO CARBURANTElitri 3,6